

### Rebar support - Galvanized steel

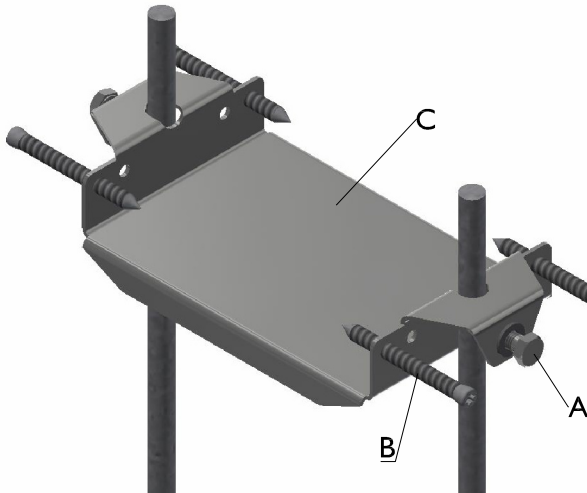

#### **Product Features:**

- Suitable to use with NW100 channels.
- Manufactured from galvanized steel

#### **Installation:**

- The rebar support shall be installed in accordance with the manufacturer's installation instructions and recommendations.

Use #30 TORX screwdriver bit



The rebar support makes height adjustment and positioning easy. A clamping system that fits around the profiled channel details.

Rebar is used to achieve the correct height.

One device per joint is required. To complete an installation using rebar support the installer will need one more rebar support than channel. If the project calls for 10 channels then 11 rebar supports will be needed (1 per channel + 1 for the end channel).

1. Drive #4 rebar into ground to hold the installation rebar support. Screw installation device to rebar at required height. Use bolt A.
2. Set channels in position over the rebar support body C.
3. Using a #30 TORX screwdriver bit, tighten the screws carefully onto the channel. Component B.
4. Adjust all wing nuts and fasteners so that the channels are held securely at the correct and level installation height. Bolts A and B.
5. Repeat for additional channels.
6. Each rebar support secures 2 adjoining channels which sit on top of the rebar support and in-between the clip clamping teeth. Rebar clip is positioned at the channel seam.

Rebar Support: 19010902

